

Shear Induced Crystallization through Altering Flow Area of Polymer Melt in Additive Manufacturing

MODEL

The proposed mechanism using the two attached parts gives the ability to control the volume of flow, which as a result gives the ability to control the amount of shear rate applied to the polymer melt, before it gets printed. The application of different shear rate values controls the evolution of crystalline region among the produced product. Resulting in the tunability of crystalline evolution spatially.

Figure 2 has a schematic of the extrusion based 3D printer. The polymer melt flow area inside the mount with a conical cavity is controlled by the attached conical tip. By moving the mount in z-direction the overall polymer melt flow area is changed. Through altering the height of the mount, the cavity volume between the mount and the conical tip changes.

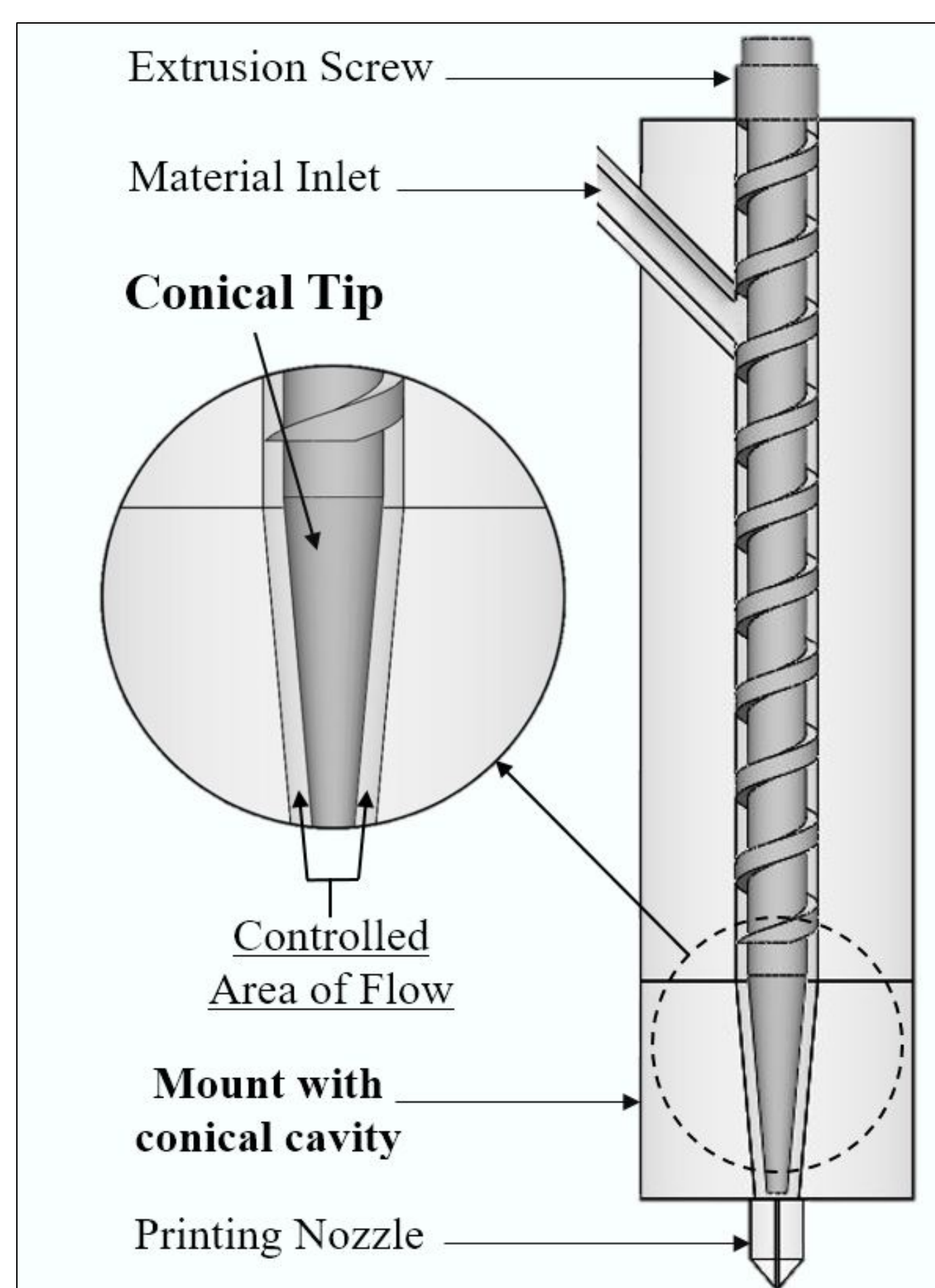

Figure 2 – Proposed Novel Technique

ANALYSIS

Figure 3 is an example of two different settings of the proposed mechanism shown in a vertical cross sectional profile. The mount on the first setting is set higher, which gives a smaller cavity (C_1). The second setting has a larger cavity (C_2), where the mount is set to be lower. The cavities are shown as dark or shaded spaces.

The polymer melt is to pass through the mount conical cavity before being printed. When the mount is set in its highest position, the polymer melt experiences a smaller cavity volume. On the other hand, when mount is set at its lowest position, the polymer melt experiences a bigger cavity volume.

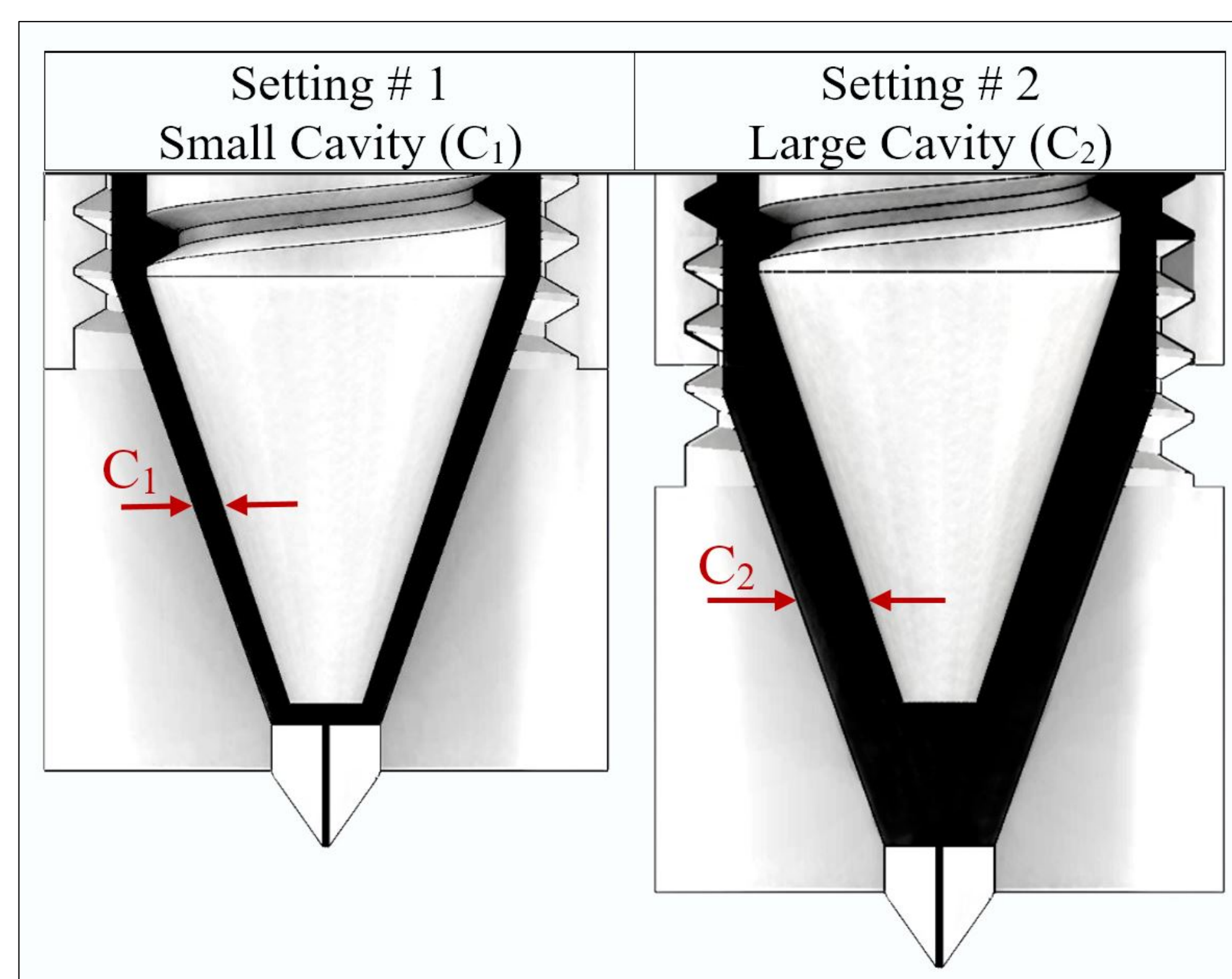

Figure 3 – Different Settings Schematics

**Hussam Noor, Khalid Alqosaibi,
Alaauldeen Duhduh**
Advisor: **John P. Coulter**

*Manufacturing Science Laboratory, Lehigh University
Bethlehem, PA*

ABSTRACT

- ❑ A novel technique is established to tune the final product's rheological properties using additive manufacturing.
- ❑ The effect of the application of shear on the polymer melt is investigated analytically.
- ❑ It has been hypothesized that the confinement will induce an additional translational shear on the polymer the degree of which can be controlled by the gap between the conical cavity and the conical extruder tip.

METHODOLOGY

The proposed novel technique is aimed at optimizing the polymer material properties by controlling the shear rate that polymer melt is experiencing during the printing process.

An extrusion based 3D printer was utilized and upgraded to perform the novel technique proposed. A mount with a conical cavity is introduced along with a conical shaped tip attached the extrusion screw are installed in the utilized printer. Figure 1 shows a schematic of the two upgraded parts.

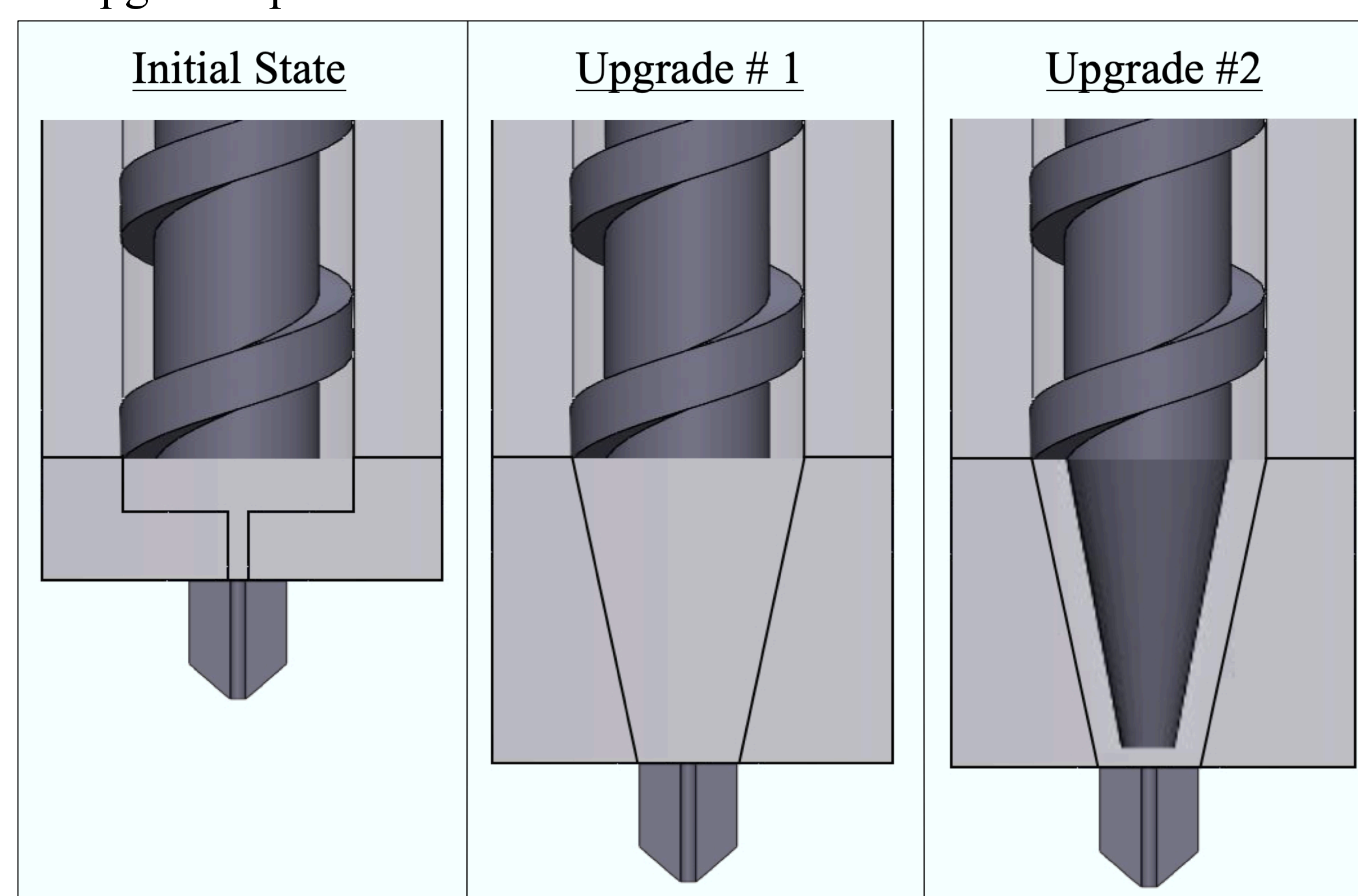

Figure 1 – Upgrading Stages

SIMULATION

The effect of changing the polymer melt flow area on shear rate was studied via a simulation software to support the hypothesis. A number of simulation studies were performed for different flow areas. The flow areas were varied by varying the inner diameter for fixed outer diameter and the resultant shear rate profiles were compared for 4 case scenarios: a 0.5 mm, 1 mm, 2 mm, and 4 mm difference in diameter.

In figure 4, a combination of the results – horizontal cross sectional contours – are presented along with a legend bar with the corresponding values of shear rate in each case. The number assigned to the arrows are the difference between the outer diameter and the inner diameter of the volume of the flow inside the cavity measured in millimeters.

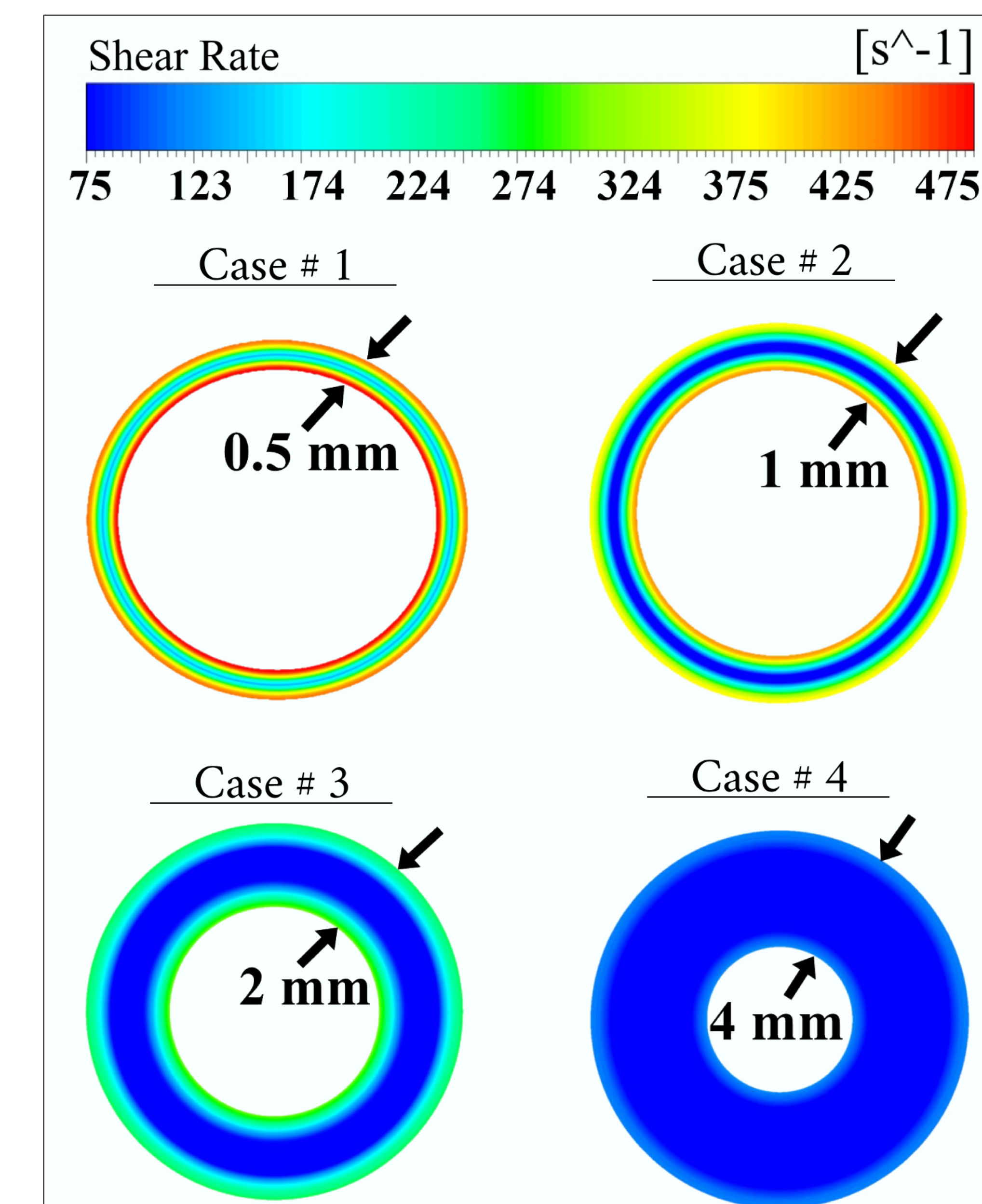

Figure 4 – Simulation Results

CONCLUSION & FUTURE WORK

- ❑ The numerical simulations indicate that the shear rates can be changed dramatically by confining the polymer flow to specific thicknesses.
- ❑ Tunable temporal control of melt rheology is achieved, which plays a critical role in the localized evolution of molecular orientation and crystallization kinetics during additive manufacturing processes.
- ❑ An experimental validation is undergoing now at Lehigh University.

Shear Induced Crystallization through Altering Flow Area of Polymer Melt in Additive Manufacturing

^{1,2}Hussam Noor, ^{1,3}Khalid Alqosaibi, ¹Alauldeen Duhduh, ¹Animesh Kundu, ¹John Coulter

¹*Manufacturing Science Laboratory*

Department of Mechanical Engineering and Mechanics

Lehigh University; Bethlehem, Pa 18015

²*Taibah University, Madinah, KSA, hhnnoor@taibahu.edu.sa*

³*King Saud University, Riyadh, KSA, kalqosaibi@ksu.edu.sa*

ABSTRACT

Additive manufacturing is a new paradigm of fabricating products. The ability to build near-net shapes by depositing layer by layer in additive manufacturing have provided a time and energy efficient processing strategy whose full potential is yet to be realized.

A novel patent pending additive manufacturing technique called “Rheoprinting” has been developed at Lehigh University [1]. It is based on an extrusion deposition 3D printer. An innovative rotating nozzle is introduced to control temporal shear rate on the molten polymer strand as it is printed on a substrate. The controlled shear alters the melt rheology, which in turn controls the evolution of important parameters such as molecular orientation, crystallinity, and filler distribution/orientation in the printed parts. The temporal control of shear translates to spatial control of melt rheology during rheoprinting. Thus, the localized evolution of molecular orientation and nucleation/crystallization kinetics as well as the mechanical and optical properties can be precisely controlled during the additive manufacturing process [2].

This research is focused on semi crystalline poly-lactic acid (PLA), a plant based biodegradable polymer used in many medical implants and other components. In this study, the effect of application of shear on the PLA is investigated analytically with primary focus on the role of the confinement of the PLA melt at the tip of extrusion nozzle. This is achieved by introducing a cone threaded to the tip of the extruder in a conical cavity whose diameter can be varied.

It has been hypothesized that the confinement will induce an additional translational shear on the polymer the degree of which can be controlled by the gap between the conical cavity and the conical extruder tip. The analytical modeling results indicate that this strategy can increase the induced shear rate by a factor of four. Resulting in controllability of crystalline evolution [3].

Keywords: rheoprinting, additive manufacturing, PLA, crystallinity.

1 INTRODUCTION

Over the last century and half, humans have been using products made of polymer in their everyday lives. Although most of the polymer used petroleum based and derived synthetically, it is notable that there are types of polymers that are natural made such as cellulose. For fabricating smaller products, an injection molding process is used. In contrast, an extrusion process is commonly utilized to fabricate larger parts.

The advent of additive manufacturing has enabled a breakthrough in the production of polymer based products. This process has allowed the tuning of the product’s properties on a region based method. In the contrary of mass production processes such as molding and extrusion, additive manufacturing has allowed the capability to control material properties at different regions among the same product.

The scope of this research is on a novel technique established to tune the final product’s rheological properties using additive manufacturing. The technique is applied on an additive manufacturing machine with an inclusive extrusion mechanism. The hypothesis is that through altering the flow area of the polymer melt, crystallization is induced as a result of the application of shear rate. An in depth numerical study is developed to study the effect of altering the flow area of polymer melt. The results are discussed with feedback given along with future work suggestions.

2 METHODOLOGY

The proposed novel technique is aimed at optimizing the polymer material properties by controlling the shear rate that polymer melt is experiencing during the printing process.

An extrusion based 3D printer was utilized in this study. Originally, the machine had a mount attached to the barrel containing an inclusive extrusion screw. The mount had a T shaped cavity on the side view. The proposed mechanism requires a taller mount to increase the overall affected area while the T shaped cavity to be integrated into a conical cavity. In addition, a conical shaped tip to be attached at the end of the extrusion screw mimicking the conical cavity to provide controllability of the affect area. Figure 1 shows the

progression of the upgrades applied virtually to the existing machine. The upgraded mount allows the ability to be moved upward and downward. The purpose of the two upgraded pieces is to control the area of polymer melt flow by moving the mount.

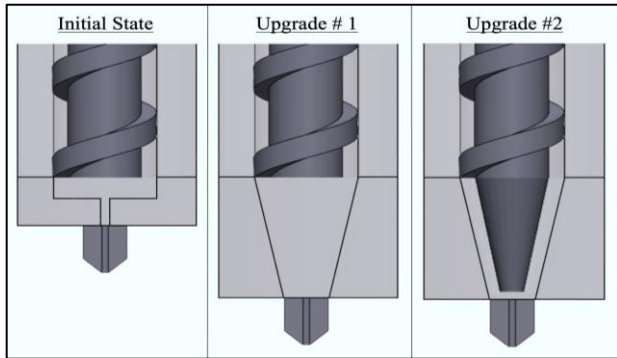

Figure 1: Schematic of the virtual upgrades to apply proposed mechanism.

The proposed mechanism using the two attached parts gives the ability to control the volume of flow, which as a result gives the ability to control the amount of shear rate applied to the polymer melt, before it gets printed. The application of different shear rate values controls the evolution of crystalline region among the produced product [4]. Resulting in the tunability of crystalline evolution at different regions among the same product [5].

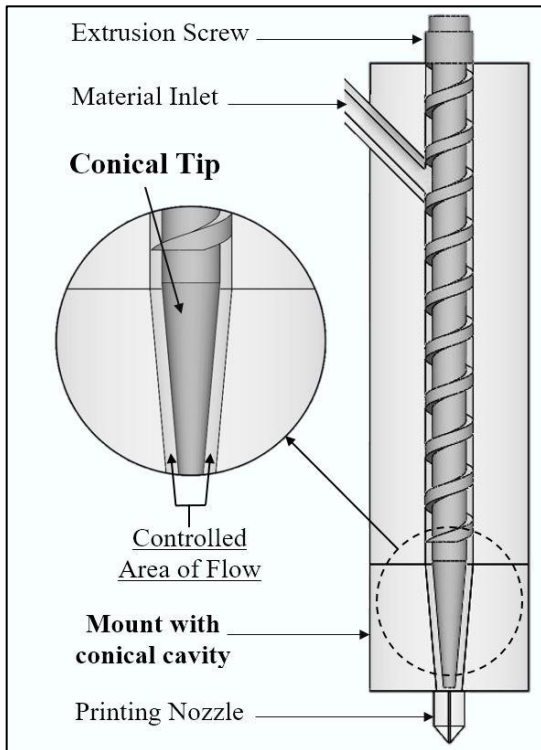

Figure 2: Schematic of the novel extrusion based 3D printer utilized in this study.

Figure 2 shows a schematic of the extrusion based 3D printer used in this study. The area of interest lies right below the extrusion screw. The polymer melt flow area inside the mount with a conical cavity is controlled by the attached conical tip. By moving the mount upward and downward the overall polymer melt flow area could be changed. Through altering the height of the mount, the cavity volume between the mount and the conical tip was changing.

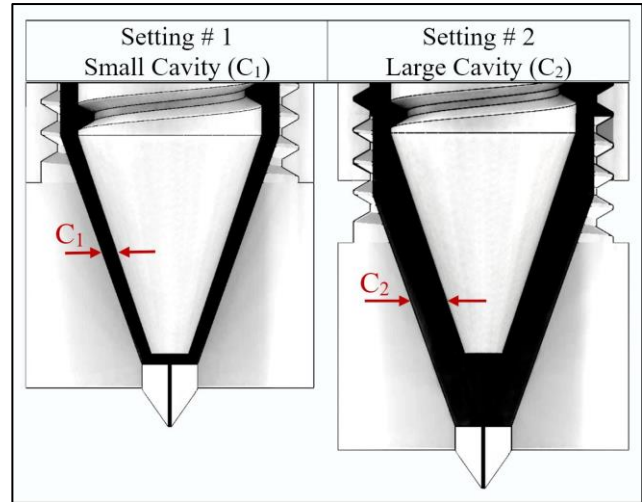

Figure 3: Schematic of two different settings using the mechanism proposed.

Figure 3 is an example of two different settings of the proposed mechanism shown in a vertical cross sectional profile. The mount on the first setting is set higher, which gives a smaller cavity (C_1). The second setting has a larger cavity (C_2), where the mount is set to be lower. The cavities are shown as dark or shaded spaces. The polymer melt is to pass through the mount conical cavity before being printed.

When the mount is set in its highest position, the polymer melt experiences a smaller cavity volume. On the other hand, when mount is set at its lowest position, the polymer melt experiences a bigger cavity volume.

A CAD model of the design modification was developed. The model was then imported into a simulation software to analyze and study the effects on the polymer melt due to changing the area of flow.

3 NUMERICAL SIMULATION

The effect of changing the polymer melt flow area on shear rate was studied via a simulation software to support the hypothesis. A number of simulation studies were performed for different flow areas. The flow areas were varied by varying the inner diameter for fixed outer diameter and the resultant shear rate profiles were compared for 4 case scenarios: a 0.5 mm, 1 mm, 2 mm, and 4 mm difference in diameter.

Ansys Fluent software was utilized to analyze the four cases. The software provides a convenient means to study

transient cases which allows the analysis of polymer melt flow behavior.

The equation used in the software for numerical calculation was the Cross Williams-Landel-Ferry (Cross-WLF Model) shown as equation (1) below. The equation used to calculate the viscosity is shown below as equation (2).

$$\eta = \eta_0 / \left[1 + \left(\frac{\eta_0 \dot{\gamma}}{\tau^*} \right)^{1-n} \right] \quad (1)$$

$$\eta_0 = D_1 \cdot \exp \left[\frac{-A_1(T-T^*)}{A_2+(T-T^*)} \right] \quad (2)$$

$$T^* = D_2 + D_3 p \quad (3)$$

where:

η = Melt viscosity (Pa-Sec)

η_0 = Zero shear viscosity (Pa-sec)

T = Temperature (K)

T^* = Glass transition temperature (K)

p = Pressure (Pa)

Simulations utilizing Ansys Fluent software were performed and the four cases were analyzed and studied. Comparing the results of the four cases, a notable change in the amount of shear rate in each case is present.

3.1 Material

The material used in this study is Ingeo 3052D, a grade of PLA manufactured by NatureWorks LLC. The material has the ability to crystallize during processing. Crystallinity behavior of the polymer depends on the processing conditions [6].

The relevant non-Newtonian fluid constants for Ingeo 3052D were obtained from the Mold Flow software database. These values were utilized as inputs to calculate zero shear viscosity in Ansys Fluent. The value of zero shear viscosity set a base to calculating the different values of viscosities at different shear rate values using the Cross Law Model.

Mold Flow Dara for PLA 3052D	
Constant	Value
n	0.3846
τ^*	129 kPa
D_1	2.045e+07 Pa-sec
D_2	373.15 K
D_3	0 K/Pa
A_1	16.71
A_2	51.6 K

Table 1: Material constants.

4 RESULTS AND DISCUSSION

The simulation results showed a strong correlation between the thickness of the polymer melt and the resultant shear rates on the polymer melt. To analyze the differences in shear rate amounts for the four different case scenarios, a horizontal cross section contour profile was obtained around the middle of the conical cavity for each setting.

It is important to note that the conical tip had a clockwise rotation speed similar to the extrusion screw rotational speed. In this case study, the screw and conical tip rotational speed was set at 100 RPMs. So, higher shear rate values were expected near the walls of the conical tip.

In figure 4, a combination of the results – horizontal cross sectional contours – are presented along with a legend bar with the corresponding values of shear rate in each case. The number assigned to the arrows are the difference between the outer diameter and the inner diameter of the volume of the flow inside the cavity measured in millimeters.

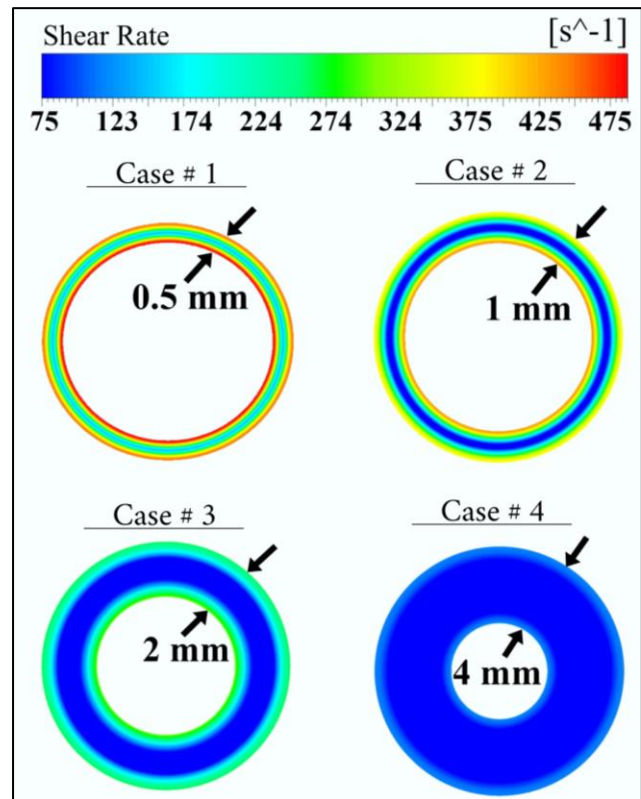

Figure 4: Cross sectional contours – results of simulations.

In scenario 1, the difference between the outer diameter and the inner diameter of the flow cavity was 0.5 mm. The highest shear rate values were highest among the four cases. A maximum shear rate value of 475 s⁻¹ was observed at adjacent to the inner diameter.

In scenario 2, the difference between outer and inner diameter was 1mm and a maximum shear rate value of ~ 400 s⁻¹ was observed in the similar region as in scenario 1.

Case scenario 3 had 2 mm difference in inner and outer diameter. This case had a lower range of shear rate value and it has a maximum value of 230 s^{-1} .

Finally, case 4, had a 4 mm difference between outer and inner diameter of the melt flow cavity. This case had the lowest values of shear rate with a maximum of 120 s^{-1} .

It is obvious from the results of the simulations utilized that the higher the mount is the higher the resultant shear rate values are. And, clearly, the lower the mount is the lower the resultant shear rate values are. Thus, the proposed mechanism allowed controllability of amount of shear rate applied to the polymer melt during processing.

Figure 5 shows the values of shear rate applied to each case. It shows clearly how shear rate is varying among the four different cases.

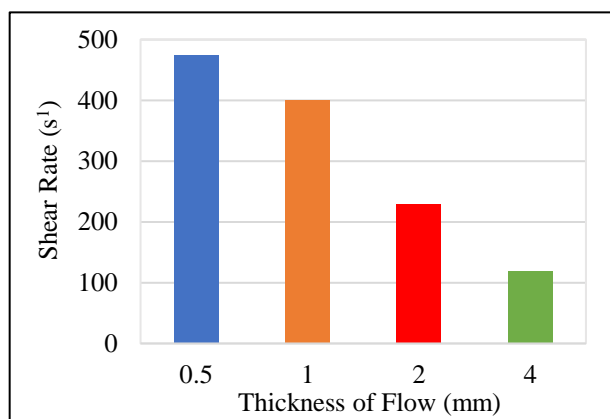

Figure 5: Cross sectional contours – results of simulations.

The application of shear rate to a polymer melt affects the molecular alignment which affects the crystallinity in the polymer (semicrystalline) melt as it solidifies [5]. Thus, by confining the polymer melt during 3D printing it would be possible to control the melt rheology leading to temporal/spatial control of crystallinity in the printed part [7]. Also, several reports by researchers have proven that the crystalline region of PLA were more resistant to degradation when compared to the amorphous regions, proving that the degradation rate decreases with an increase in crystallinity [8].

5 CONCLUSION

A novel additive manufacturing technique is proposed for printing polymers with controlled and spatially varying rheological properties. The technique involves altering the flow area of the polymer melt inside the nozzle of the printing head and applying a controlled shear on the polymer melt. The numerical simulations indicate that the shear rates can be changed dramatically by confining the polymer flow to specific thicknesses. The ability to control shear rates on the polymer melt would provide a strategy for tunable temporal control of melt rheology, which plays a critical role in the localized evolution of molecular orientation (for all

polymers) and crystallization kinetics (for semicrystalline polymers) during additive manufacturing processes.

The simulation results indicated a promising future for the proposed mechanism. An experimental study to analyze the development of crystallinity in semicrystalline grades of PLA under various experimental conditions is underway.

REFERENCES

- [1] A. Duhduh, I.H. Jaafar, J.P. Coulter, Additive “4D-RheoPrinting” for the Manufacture of Enhanced Biomaterial Products, (2017).
- [2] M. Boutaous, P. Bourgin, M. Zinet, Thermally and flow induced crystallization of polymers at low shear rate, *J. Non-Newton. Fluid Mech.* 165 (2010) 227–237. doi:10.1016/j.jnnfm.2009.12.005.
- [3] Z. Wang, Z. Ma, L. Li, Flow-Induced Crystallization of Polymers: Molecular and Thermodynamic Considerations, *Macromolecules.* 49 (2016) 1505–1517. doi:10.1021/acs.macromol.5b02688.
- [4] A. Duhduh, A.A. Rajhi, J.P. Coulter, The impact of the “4d-Rheoprinting” additive manufacturing technique on molecular orientation and thermal properties of polymeric parts, (2018).
- [5] T.W. Haas, B. Maxwell, Effects of shear stress on the crystallization of linear polyethylene and polybutene-1, *Polym. Eng. Sci.* 9 (1969) 225–241. doi:10.1002/pen.760090402.
- [6] L. Ford, Ingeo Biopolymer 3052D Technical Data Sheet.
- [7] L. Běhálek, M. Maršálová, P. Lenfeld, J. Habr, J. Bobek, M. Seidl, STUDY OF CRYSTALLIZATION OF POLYLACTIC ACID COMPOSITES AND NANOCOMPOSITES WITH NATURAL FIBRES BY DSC METHOD, (2013).
- [8] Y. Wang, J.F. Mano, Stereocomplexation and morphology of enantiomeric poly(lactic acid)s with moderate-molecular-weight, *J. Appl. Polym. Sci.* 107 (2008) 1621–1627. doi:10.1002/app.27260.